

## Example Layout Drawing:

- L shaped layout with 3X 10 ft rails

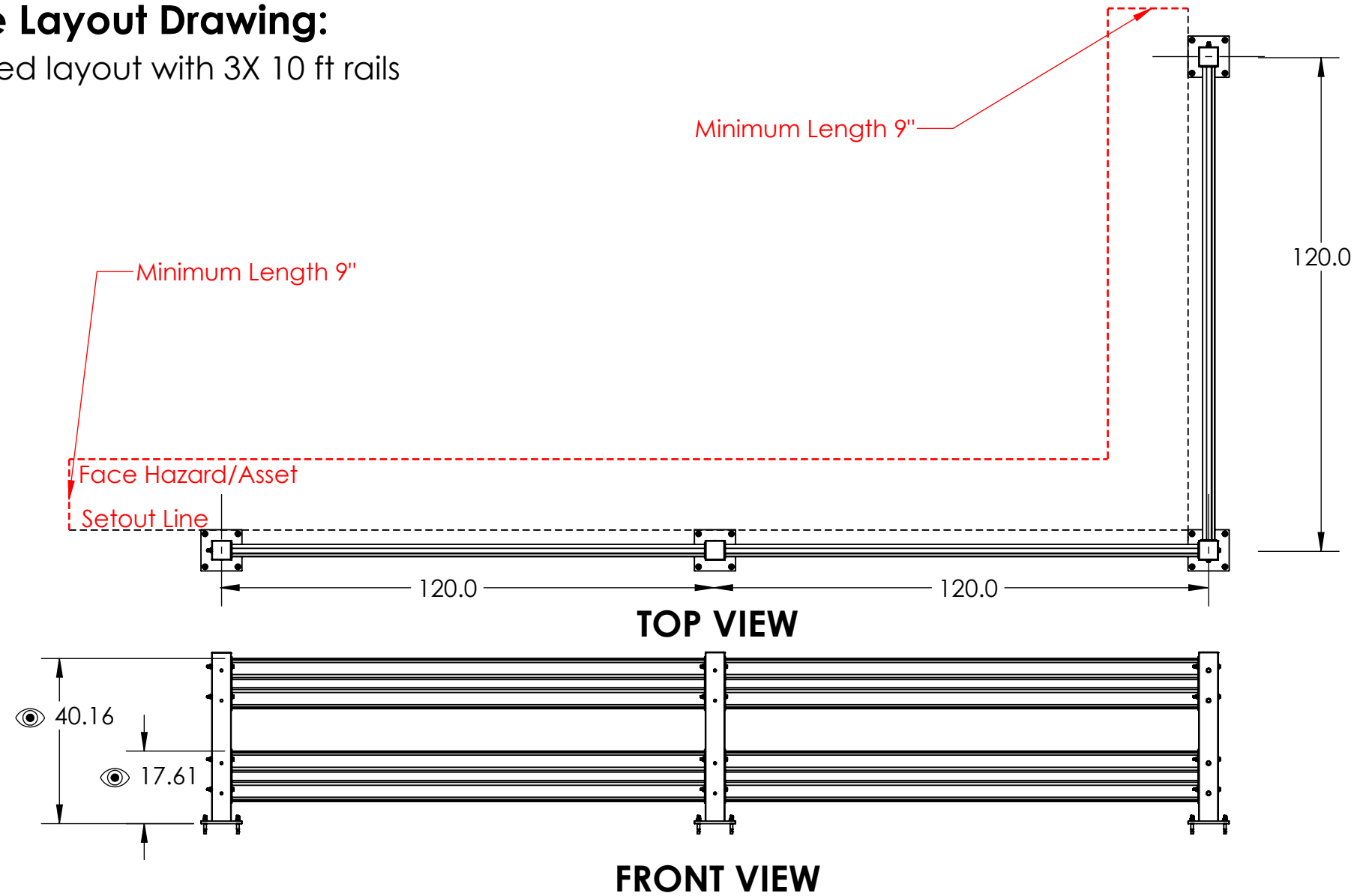

### RAIL OPTIONS

DESCRIPTION	PART NO	POST CENTER TO CENTER (IN)	LENGTH (IN)	WEIGHT EA (lbs)
2ft Rail	A0010	24	19.28	16.57
3ft Rail	A0009	36	31.28	24.07
4ft Rail	A0008	48	43.28	31.57
5ft Rail	A0007	60	55.28	39.1
6ft Rail	A0006	72	67.28	46.58
7ft Rail	A0005	84	79.28	54.1
8ft Rail	A0004	96	91.28	61.58
9ft Rail	A0003	108	103.28	69.1
10ft Rail	A0001	120	115.28	76.59

### POST

DESCRIPTION	PART NO	LENGTH (IN)	WEIGHT EA (lbs)
Double Post	A0013	41.55	56.7



#### COMPANY:

Guardrail Online LLC  
1309 COFFEEN AVE STE 1200, SHERIDAN, WY 82801

#### PRODUCT:

**Double Height Rail**

#### STANDARD:

System is intended for impacts up to 10,000 lb at 4 mph under controlled conditions. Actual performance is dependant on concrete strength, slab thickness, anchor type, embedment depth, and proper installation

#### DOCUMENT CONTROL

REV.	DATE	DESCRIPTION
0	20251228	Initial Release
1	20260228	Updated as per engineer comments
2	20260404	Updated as per engineer comments
3	20260425	Updated as per engineer comments

DRAWN BY:	TA	PAPER SIZE	B
APPROVED:	JF	SHEET NO.	1/6
DATE	20260425	SCALE	N.T.S.

DRAWING TYPE: General Arrangement

DRAWING NUMBER: GA-002

## Assembly Step 1:

- Mark set out line minimum 9 inches from the face of hazard or asset
- The back of the base plate will align with this as shown

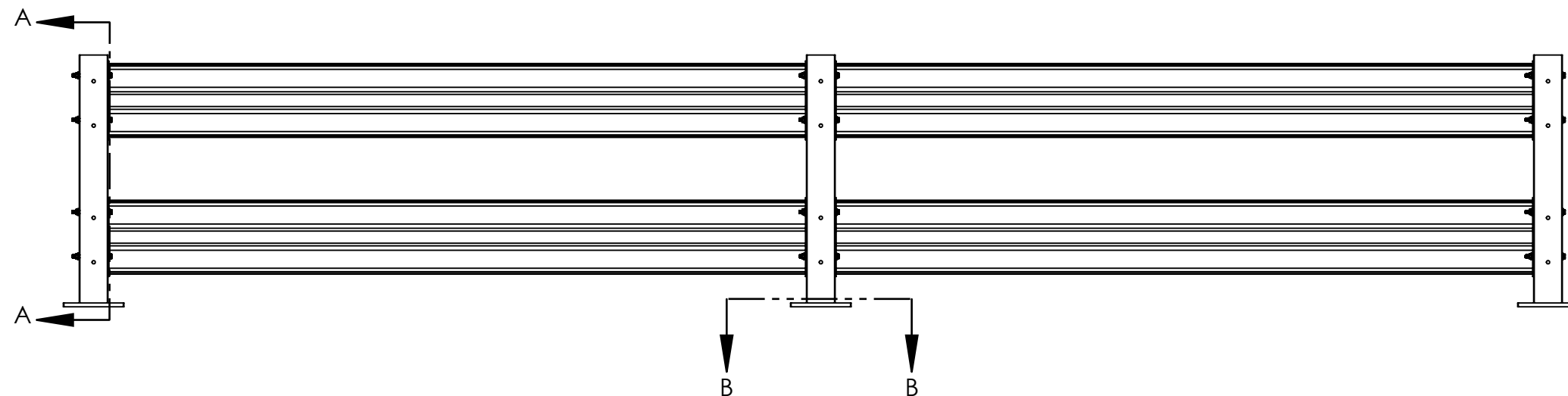
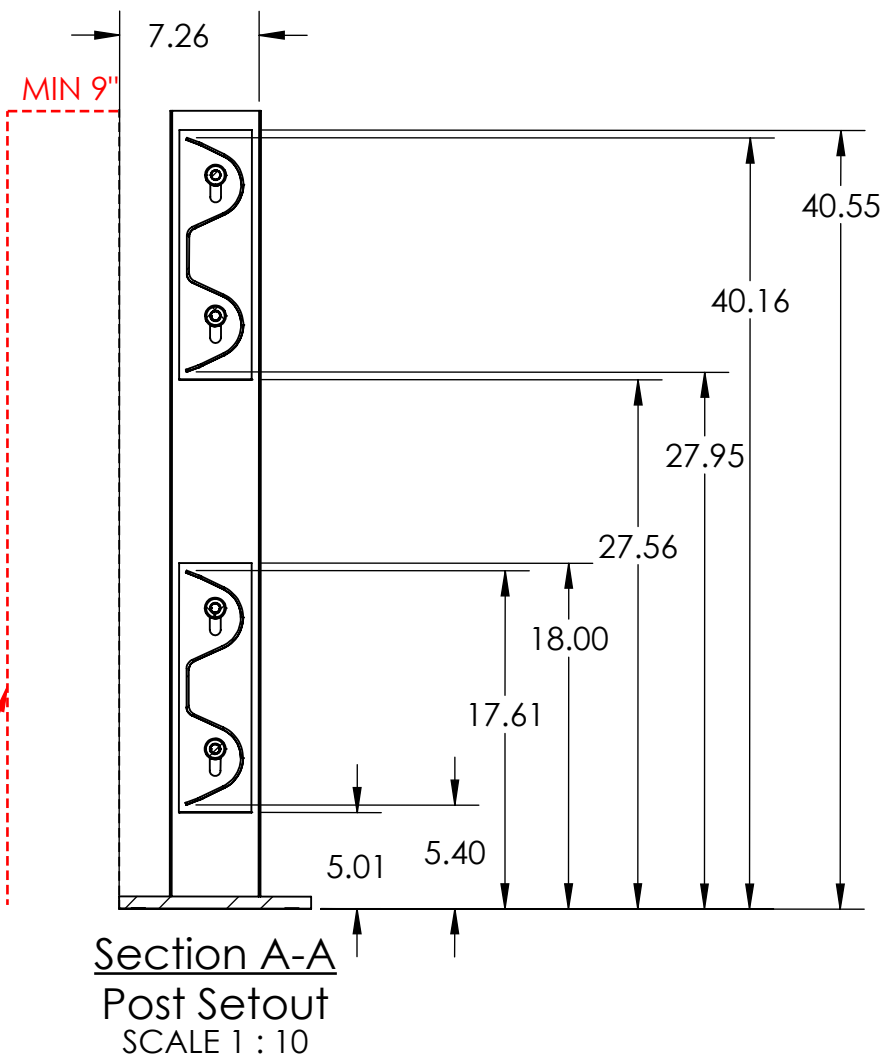
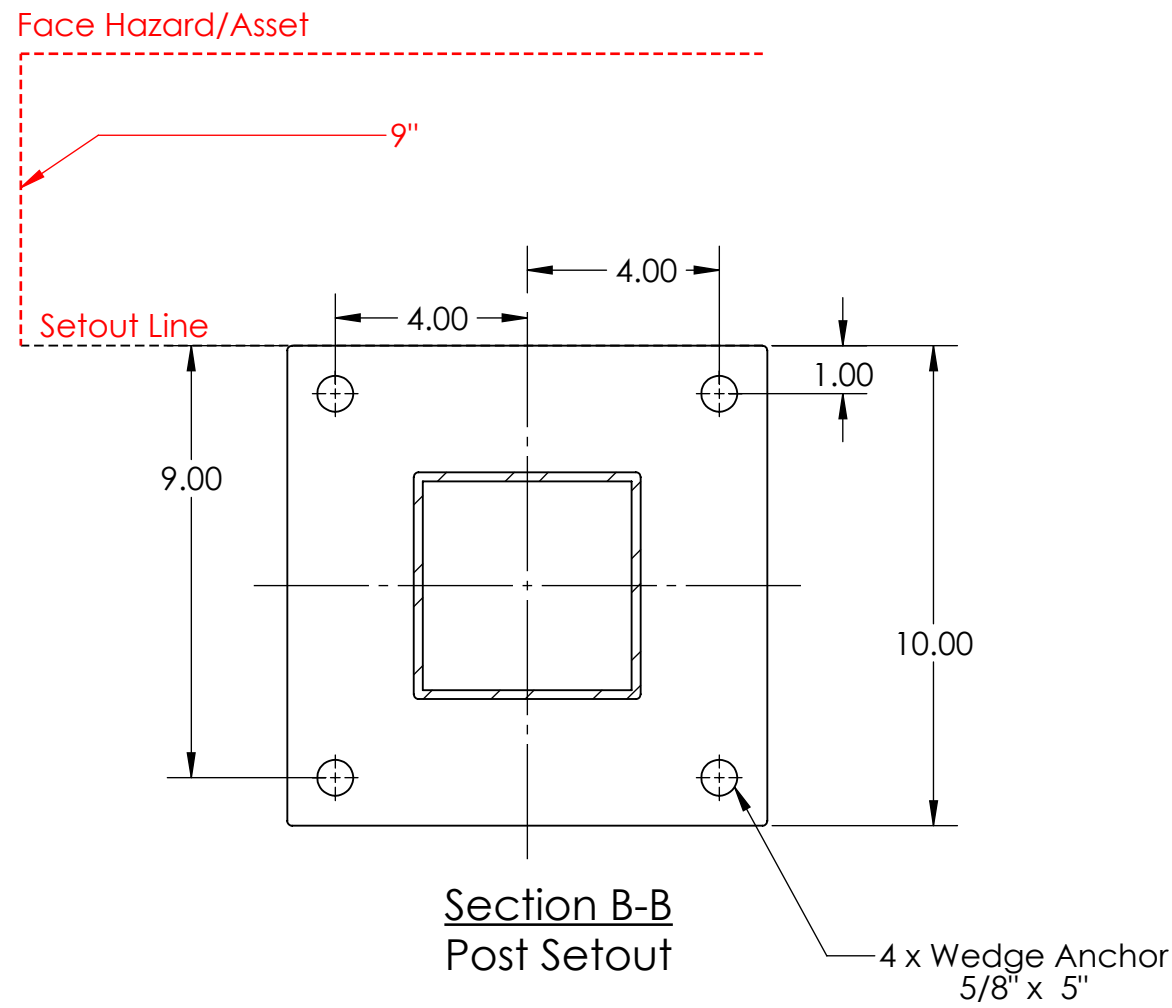

### COMPANY:

Guardrail Online LLC  
1309 COFFEEN AVE STE 1200, SHERIDAN, WY 82801

### PRODUCT:

**Double Height Rail**

### STANDARD:

System is intended for impacts up to 10,000 lb at 4 mph under controlled conditions. Actual performance is dependant on concrete strength, slab thickness, anchor type, embedment depth, and proper installation

### DOCUMENT CONTROL

REV.	DATE	DESCRIPTION
0	20251228	Initial Release
1	20260228	Updated as per engineer comments
2	20260404	Updated as per engineer comments
3	20260425	Updated as per engineer comments

DRAWN BY:	TA	PAPER SIZE	B
APPROVED:	JF	SHEET NO.	2/6
DATE	20260425	SCALE	N.T.S.

DRAWING TYPE	General Arrangement
--------------	---------------------

DRAWING NUMBER	GA-002
----------------	--------

## ASSEMBLY STEP 2:

- Assemble post and rail as per below procedure
- Double concave side of corrugation to face asset/hazard
- Only finger tighten bolts until full run is installed
- Washer to be installed both sides typically

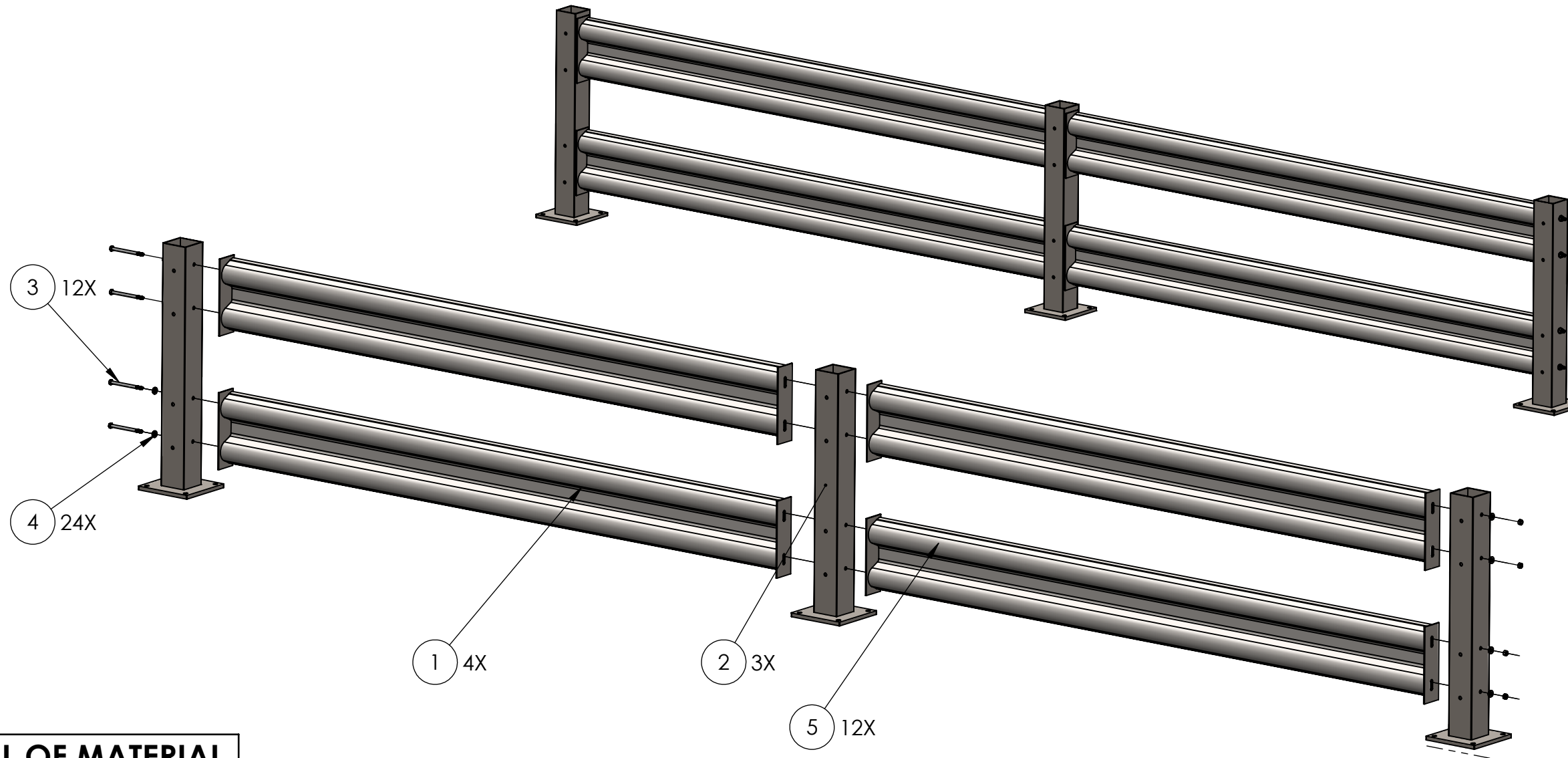

### BILL OF MATERIAL

ITEM NO.	PART NUMBER	DESCRIPTION	LENGTH (IN)	WEIGHT EA (lbs)	QTY.
1	A0001	10 Foot Rail	115.28	76.59	4
2	A0013	Double Post	41.55	56.7	3
3	P0023	Hex Cap Screw, M12-1.75X 6-3/10", Grade 8.8	6.3	0.32	12
4	P0021	Washer OD 0.95 in , ID 0.51 in	0.95	0.012	24
5	P0022	NUT, HEX, M12-1.75 Thread Size	0.83	0.03	12



#### COMPANY:

Guardrail Online LLC  
1309 COFFEEN AVE STE 1200, SHERIDAN, WY 82801

#### PRODUCT:

**Double Height Rail**

#### STANDARD:

System is intended for impacts up to 10,000 lb at 4 mph under controlled conditions. Actual performance is dependant on concrete strength, slab thickness, anchor type, embedment depth, and proper installation

#### DOCUMENT CONTROL

REV.	DATE	DESCRIPTION
0	20251228	Initial Release
1	20260228	Updated as per engineer comments
2	20260404	Updated as per engineer comments
3	20260425	Updated as per engineer comments

DRAWN BY:	TA	PAPER SIZE	B
APPROVED:	JF	SHEET NO.	3/6
DATE	20260425	SCALE	N.T.S.

DRAWING TYPE	General Arrangement
--------------	---------------------

DRAWING NUMBER	GA-002
----------------	--------

# ASSEMBLY STEP 3

- Assemble another rail perpendicular to the previous using below procedure

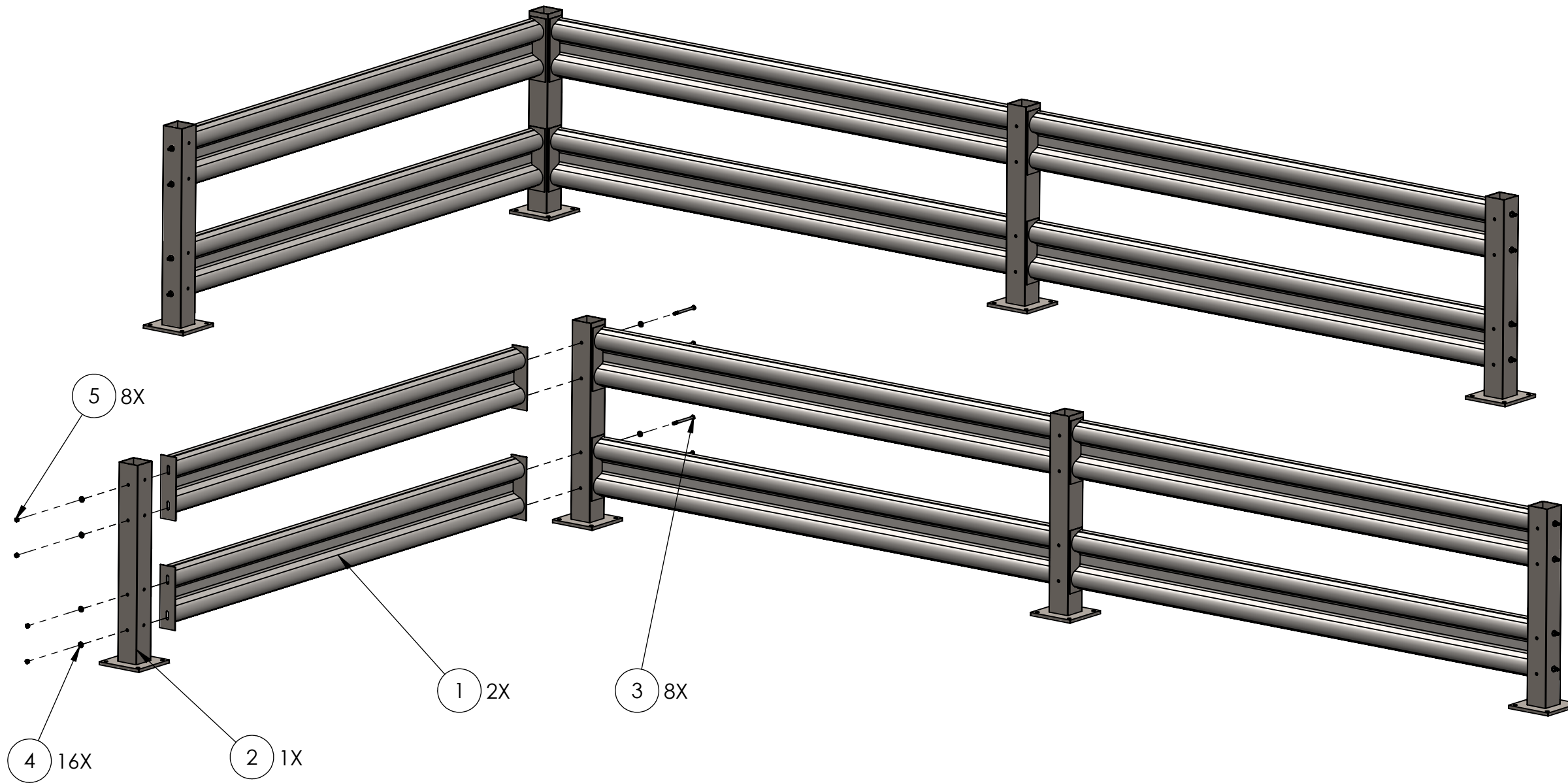

BILL OF MATERIAL					
ITEM NO.	PART NUMBER	DESCRIPTION	LENGTH (IN)	WEIGHT EA (lbs)	QTY.
1	A0001	10 Foot Rail	115.28	76.59	2
2	A0013	Double Post	41.55	56.7	1
3	P0023	Hex Cap Screw, M12-1.75X 6-3/10", Grade 8.8	6.3	0.32	8
4	P0021	Washer OD 0.95 in , ID 0.51 in	0.95	0.012	16
5	P0022	NUT, HEX, M12-1.75 Thread Size	0.83	0.03	8



**COMPANY:**  
Guardrail Online LLC  
1309 COFFEEN AVE STE 1200, SHERIDAN, WY 82801

**PRODUCT:**  
**Double Height Rail**

**STANDARD:**  
System is intended for impacts up to 10,000 lb at 4 mph under controlled conditions. Actual performance is dependant on concrete strength, slab thickness, anchor type, embedment depth, and proper installation

DOCUMENT CONTROL		
REV.	DATE	DESCRIPTION
0	20251228	Initial Release
1	20260228	Updated as per engineer comments
2	20260404	Updated as per engineer comments
3	20260425	Updated as per engineer comments

DRAWN BY:	TA	PAPER SIZE	B
APPROVED:	JF	SHEET NO.	5/6
DATE	20260425	SCALE	N.T.S.

DRAWING TYPE: General Arrangement

DRAWING NUMBER: GA-002

# ASSEMBLY STEP 4

- Install anchor bolts, hole plugs and caps on post as per below procedure
- Adjust rails as required to ensure all rails are level, then complete the final tightening of bolts



**COMPANY:**

Guardrail Online LLC  
1309 COFFEEN AVE STE 1200, SHERIDAN, WY 82801

**PRODUCT:**

**Double Height Rail**

**STANDARD:**

System is intended for impacts up to 10,000 lb at 4 mph under controlled conditions. Actual performance is dependant on concrete strength, slab thickness, anchor type, embedment depth, and proper installation

**DOCUMENT CONTROL**

REV.	DATE	DESCRIPTION
0	20251228	Initial Release
1	20260228	Updated as per engineer comments
2	20260404	Updated as per engineer comments
3	20260425	Updated as per engineer comments

DRAWN BY:	TA	PAPER SIZE	B
APPROVED:	JF	SHEET NO.	6/6
DATE	20260425	SCALE	N.T.S.

DRAWING TYPE	General Arrangement
--------------	---------------------

DRAWING NUMBER	GA-002
----------------	--------

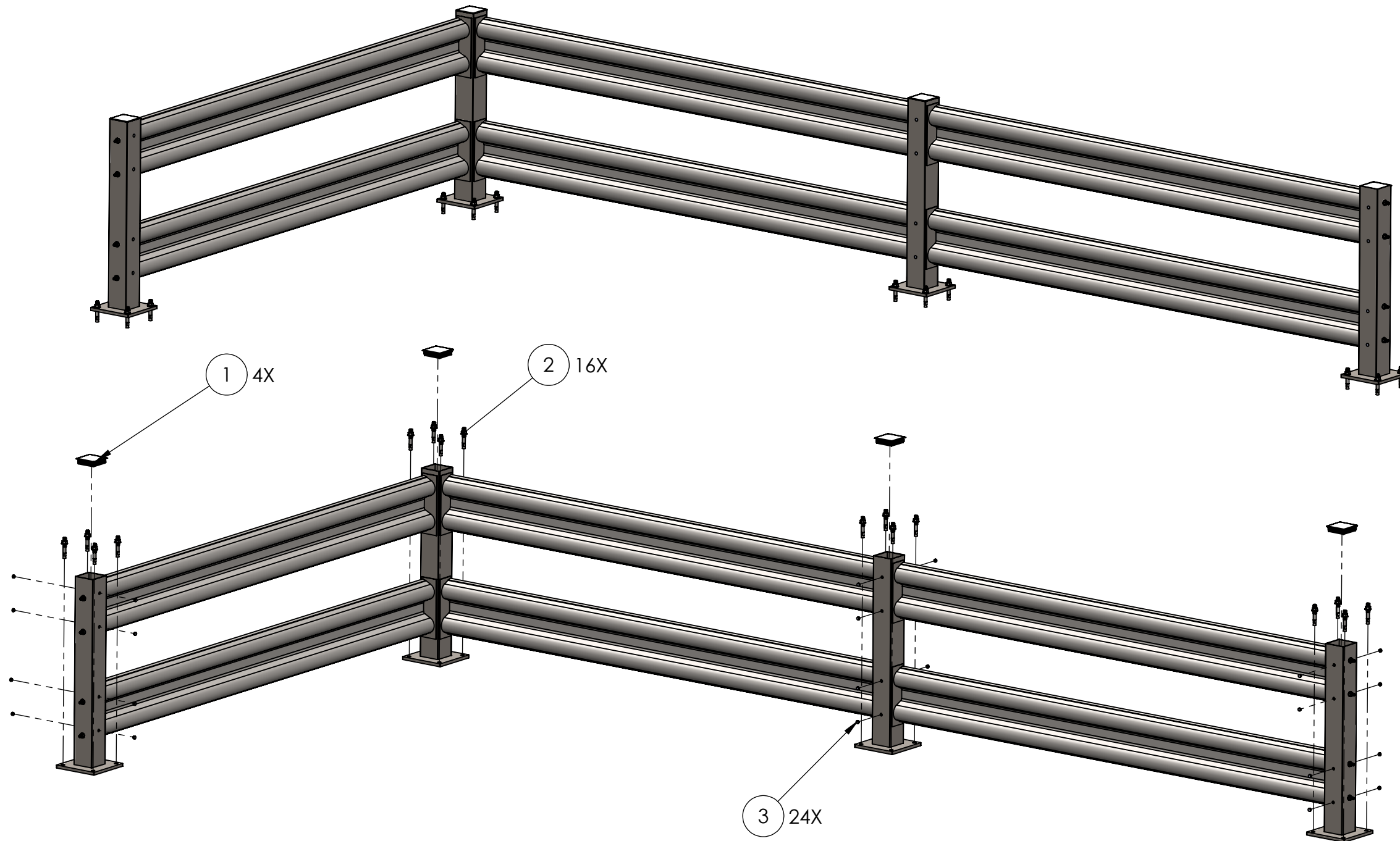

**BILL OF MATERIAL**

ITEM NO.	PART NUMBER	DESCRIPTION	LENGTH (IN)	WEIGHT EA (lb)	QTY.
1	P0024	Polyethylene Cap 4.72"x 4.72"	4.72	0.16	4
2	P0025	Wedge Anchor 5/8" x 5"	5	0.45	16
3	P0026	Hole Plug	0.65	0.018	24